



## Kato MR-130 City Ace (KRM-13H) Rough Terrain Crane (Power Jib)

### SPECIFICATION

#### Crane Specification

#### Crane Performance

Rated Lifting Capacity	5.30m Boom	13.0 Tonne @ 1.7m	(8 Parts of Line)
	9.04m Boom	6.0 Tonne @ 4.0m	(4 Parts of Line)
	12.78m Boom	6.0 Tonne @ 4.0m	(4 Parts of Line)
	16.52m Boom	5.0 Tonne @ 4.5m	(4 Parts of Line)
	20.26m Boom	4.7 Tonne @ 4.0m	(4 Parts of Line)
	24.00m Boom	3.2 Tonne @ 5.5m	(4 Parts of Line)
	3.6m Jib	1.6 Tonne @ 75°	(1 Part of Line)
	5.5m Jib	1.0 Tonne @ 70°	(1 Part of Line)
	Rooster Sheave	1.8 Tonne	(1 Part of Line)
Boom Length	5.3m - 24.0m		
Jib Length	3.6m - 5.5m		
Maximum Lifting Height Above Ground	24.8m (Boom) 30.3m (Jib)		
Line Speed (Main)	118m/min (5th layer)		
Line Speed (Auxiliary)	103m/min (3rd layer)		
Hook Speed (Main)	(Parts of Line 8): 14.75m/min (5th layer)		
Hook Speed (Auxiliary)	(Parts of Line 1): 103m/min (3rd layer)		
High Speed Lowering Rope Speed			
Main	180m/min (5th layer)		
Auxiliary	155m/min (3rd layer)		
Boom Derricking Range	-7.5° ~ 82°		
Boom Raising Speed	-7.5° ~ 82°/30 sec		
Boom Extension Speed	5.3m ~ 24.0m/65 sec		
Slewing Speed	2.4min <sup>-1</sup>		
Rear Slewing Radius	1,600 mm		

#### Crane Equipment and Structure

Boom Type	Closed 6 Stage Hydraulic Telescopic Type (Simultaneous 2 · 3 Stage, Simultaneous 4 · 5 · 6 Stage)		
Jib Type	2 Stage Type (2nd Stage Retractable) Non-Hydraulic Stage Gradient (Offset 5°~60°)		
Boom Extension Equipment	Hydraulic Cylinder (2) with Wire Rope		
Boom Derricking Equipment	Direct Press Hydraulic Cylinder Type, Flow Regulator with Pressure Compensator		
Hoist Equipment	Group 2 Single Winch, Hydraulic Motor Drive · Differential Gear Speed Reduction Type, High/Low Speed Changer Type with Automatic Brakes, Flow Regulator with Pressure Compensator		
Slewing Equipment	Hydraulic Motor Drive with Planet Gear Speed Reducer (Built-in Negative Brake)		
Slew Circle	Ball Bearing Type		
Outrigger Equipment	Type	Fully Hydraulic H Type (Float, Vertical Cylinder Model)	
	Extension Range	4,750 mm (Full Extension)	
		3,700 mm (Intermediate Extension)	
		2,700 mm (Intermediate Extension)	
		1,640 mm (Full Retraction)	
Wire Rope	Main	Non Flammable Wire Rope ø 11.2mm × 132m	
	Auxiliary	Non Flammable Wire Rope ø 11.2mm × 65m	

#### Hydraulic Equipment

Hydraulic Pump	Double Variable Plunger Type, Variable Plunger + Gear Type
Hydraulic Motor	Hoisting and Slewing: Axial Plunger Type
Control Valve	Multiple Auto Recovery Type (with Pressure Compensator, Flow Regulator)
Cylinder	Double Acting Type
Oil Reservoir	150L

**KATO**

## Kato MR-130 City Ace (KRM-13H) Rough Terrain Crane (Power Jib)

### SPECIFICATION

#### Crane Specification

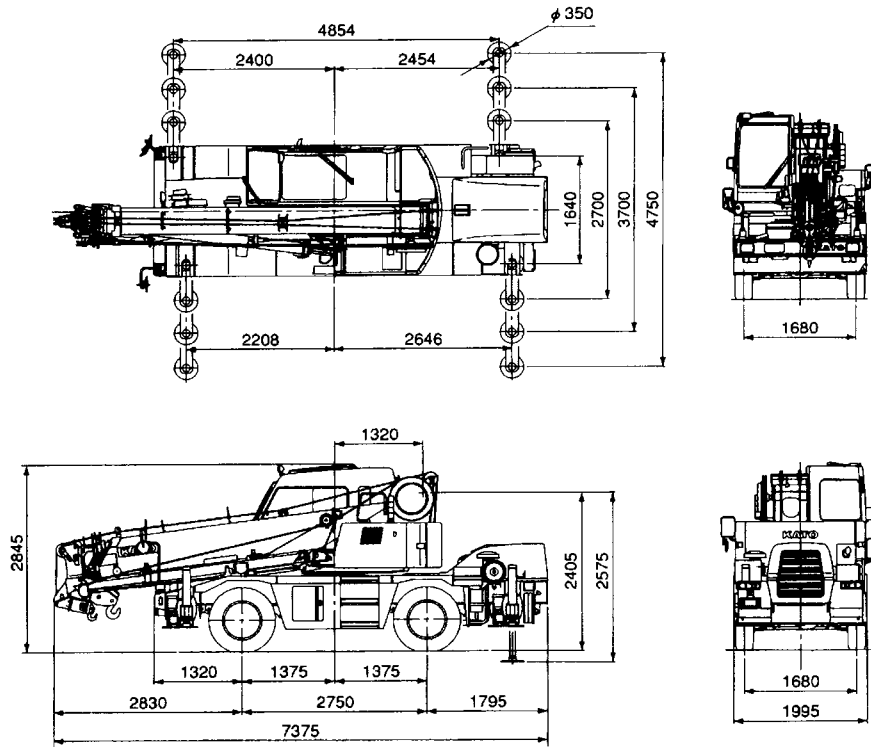

(measurement: mm)

#### Safety Equipment

ACS (with Overload Prevention/Voice Alarm Device)  
 Operation Range Limit Device  
 Outrigger Extension Automatic Detection Device  
 Boom Freefall Prevention Device  
 Overhoist Prevention Device  
 Automatic Brake Device  
 Hydraulic Safety Valve  
 Outrigger Lock Device  
 Slewing Warning Light  
 Hydraulic Fluid Overheat Alarm Device

#### Standard Equipment

Drum Revolution Indicator Device

#### Cab Components

Dehumidifying Air Conditioner,  
 Tilt/Telescopic Handle,  
 Fully Adjustable Suspension Seat (with Headrest and Armrest),  
 Power Windows (with Open Window Prevention Switch),  
 Hot and Cool Box, Intermittent Front and Roof Wipers (with Washers),  
 Lunch Table, AM/FM Clock Radio, Cigarette Lighter, Step Light,  
 Fire Extinguisher, Floor Mat

#### Optional Components

ACS Outside Display Area Display Equipment,  
 Loud Speaker, Door Visa, Winding Jam Prevention Device



## Kato MR-130 City Ace (KRM-13H) Rough Terrain Crane (Power Jib)

### SPECIFICATION

#### Carrier Specification

#### Driving Performance

Maximum Travelling Speed	49 km/hr
Uphill Ability	0.43 (tan $\theta$ )
Minimum Turning Radius	6.5m (2 Wheel Steering) 3.92m (4 Wheel Steering)

#### Weight and Dimensions

Overall Length	7,375 mm approx.
Overall Width	1,995 mm approx.
Overall Height	2,845 mm approx.
Distance Between Axles	2,750 mm approx.
Treads	Front 1,680 mm Rear 1,680 mm
Seats	1

#### Gross Vehicle Weight

Overall Weight	13,235 kg approx.
Front Axle Weight	6,410 kg approx.
Rear Axle Weight	6,825 kg approx.

#### Engine

Engine Model	Hino W04D-TF (with Intercooler Turbo)
Engine Type	Water Cooled, 4 Cycle, In-Line 4 Cylinder, Direct Injection Type Diesel Engine
Total Emission	4.009L
Maximum Power	118kW @ 2,800min <sup>-1</sup>
Maximum Torque	461N·m @ 1,600min <sup>-1</sup>

#### Carrier Components and Structure

Drive System	2 Wheel Drive (4×2), 4 Wheel Drive (4×4) Switching System	
Torque Converter	3 Components, 1 Stage (with Automatic Lock Up Mechanism)	
Transmission Type	Complete Automatic and Manual Gear Transmission Type	
Number of Gears	4 Forward Gears, 2 Reverse Gears	
Axle Type	Front	Full Floating Type, 2 Stage Reducer Type
	Rear	Full Floating Type, 2 Stage Reducer Type
Suspension	Front	Taper Leaf Spring Type (Hydraulic Lock Cylinder Type)
Components	Rear	Taper Leaf Spring Type (Hydraulic Lock Cylinder Type)
Brake	Main Brake	Dual System Combined Hydraulic Pneumatic Type, 4 Wheel Disc Brakes
Components	Park Brake	Pneumatic Type, Transmission Braking Internal Expansion Type
	Auxiliary Brake	Torque Converter Lock Up Interlocking Exhaust Retarder, Auxiliary Braking Device for Operation
Steering	Type	Complete Hydraulic Type Power Steering
Device	Mode	Front 2 Wheels, Rear 2 Wheels, Front/Back Wheels Independent (with Rear Steering Lock Mechanism)
Tyre Size	Front	275 / 80 R22.5 149 / 146J
	Rear	275 / 80 R22.5 151 / 148J
Fuel Tank Capacity	250L	
Battery	(12V-100AH) ×2	

#### Safety Components

Emergency Steering Device, Rear Wheel Steering Lock Device, Miss Shift Prevention Device, Brake Fluid Leakage Alarm Device, Auxiliary Braking Device for Operation, Suspension Lock Device, Overrun Alarm Device, Radiator Fluid Level Alarm Device

#### Optional Devices

Electric-Powered Housing Side Mirrors, Tachograph

Rated Lifting Capacity Table (1)

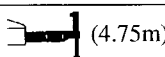
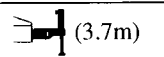
5.30m ~ 24.0m Boom												
Working Radius (m)	 (4.75m)						 (3.7m)					
	Outriggers Fully Extended (360° Full Range)						Outriggers Intermediately Extended (Over Side)					
	5.3m Boom	9.04m Boom	12.78m Boom	16.52m Boom	20.26m Boom	24.0m Boom	5.3m Boom	9.04m Boom	12.78m Boom	16.52m Boom	20.26m Boom	24.0m Boom
1.5	13.00	6.00	6.00				12.00	6.00	6.00			
1.7	13.00	6.00	6.00				12.00	6.00	6.00			
2.0	12.00	6.00	6.00	5.00			12.00	6.00	6.00	5.00		
2.5	10.00	6.00	6.00	5.00			10.00	6.00	6.00	5.00		
3.0	8.20	6.00	6.00	5.00	4.70		8.20	6.00	6.00	5.00	4.70	
3.5	7.00	6.00	6.00	5.00	4.70	3.20	7.00	6.00	6.00	5.00	4.70	3.20
4.0	6.10	6.00	6.00	5.00	4.70	3.20	6.10	6.00	6.00	5.00	4.70	3.20
4.5		5.50	5.40	5.00	4.50	3.20		5.00	5.00	5.00	4.50	3.20
5.0		5.00	4.90	4.60	4.05	3.20		4.30	4.30	4.40	4.05	3.20
5.5		4.50	4.40	4.20	3.70	3.20		3.70	3.60	3.80	3.70	3.20
6.0		4.10	4.00	3.80	3.40	3.00		3.10	3.10	3.30	3.30	3.00
6.5		3.70	3.65	3.50	3.15	2.80		2.70	2.65	2.85	2.90	2.75
7.0		3.35	3.30	3.20	2.90	2.60		2.30	2.30	2.50	2.60	2.50
8.0		<sup>2.70</sup> (7.7m)	2.70	2.70	2.50	2.25		<sup>1.85</sup> (7.7m)	1.75	1.90	2.00	2.10
9.0			2.20	2.30	2.20	1.95			1.35	1.50	1.60	1.70
10.0			1.80	1.90	1.95	1.75			1.05	1.20	1.30	1.40
11.0			1.45	1.60	1.75	1.55			0.80	1.00	1.10	1.15
12.0			<sup>1.30</sup> (11.4m)	1.40	1.50	1.40			<sup>0.65</sup> (11.4m)	0.80	0.90	0.95
13.0				1.20	1.30	1.25				0.60	0.75	0.80
14.0				1.00	1.10	1.15				0.45	0.60	0.65
15.0				0.85	0.95	1.00				0.35	0.45	0.55
16.0					0.80	0.90					0.35	0.45
17.0					0.70	0.80					0.25	0.35
18.0					0.60	0.68						0.25
19.0					<sup>0.50</sup> (18.8m)	0.58						
20.0						0.48						
21.0						0.40						
22.0						0.35						
22.5						0.32						
Critical Boom Angle	-	-	-	-	-	-	-	-	-	-	23°	36°
Standard Hook	13t Hook						13t Hook					
Hook Weight	90 kg						90 kg					
Parts of Line	8	4	4	4	4	4	8	4	4	4	4	4

(unit: metric ton)

Rated Lifting Capacity Table (2)

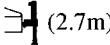
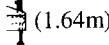
5.30m ~ 24.0m Boom												
Working Radius (m)	 (2.7m)						 (1.64m)					
	Outriggers Intermediately Extended (Over Side)						Outriggers Fully Retracted (Over Side)					
	5.3m Boom	9.04m Boom	12.78m Boom	16.52m Boom	20.26m Boom	24.0m Boom	5.3m Boom	9.04m Boom	12.78m Boom	16.52m Boom	20.26m Boom	24.0m Boom
1.5	12.00	6.00	6.00				8.00	6.00	6.00			
1.7	12.00	6.00	6.00				7.00	6.00	6.00			
2.0	12.00	6.00	6.00	5.00			5.60	5.40	5.00	4.70		
2.5	8.50	6.00	6.00	5.00			3.80	3.80	3.60	3.50		
3.0	6.00	6.00	6.00	5.00	4.70		2.80	2.80	2.70	2.70	2.60	
3.5	4.70	4.70	4.60	4.50	4.40	3.20	2.10	2.10	2.00	2.10	2.10	2.10
4.0	3.70	3.70	3.70	3.70	3.70	3.20	1.60	1.60	1.55	1.70	1.70	1.75
4.5		3.00	3.00	3.10	3.10	3.00		1.25	1.20	1.40	1.40	1.45
5.0		2.40	2.40	2.60	2.70	2.70		0.95	0.95	1.10	1.20	1.25
5.5		2.00	2.00	2.20	2.30	2.30		0.75	0.75	0.90	1.00	1.05
6.0		1.70	1.70	1.85	2.00	2.05		0.60	0.55	0.75	0.80	0.90
6.5		1.40	1.40	1.60	1.70	1.75		0.40	0.35	0.60	0.65	0.75
7.0		1.20	1.20	1.40	1.50	1.55		0.25		0.45	0.55	0.60
8.0		<sup>0.90</sup> (7.7m)	0.85	1.05	1.15	1.20						
9.0			0.60	0.80	0.90	0.95						
10.0			0.35	0.55	0.65	0.75						
11.0				0.40	0.50	0.60						
12.0				0.25	0.35	0.45						
13.0					0.20	0.30						
14.0						0.20						
15.0												
16.0												
17.0												
18.0												
Critical Boom Angle	-	-	19°	32°	44°	50°	-	20°	54°	61°	66°	70°
Standard Hook	13t Hook						13t Hook					
Hook Weight	90 kg						90 kg					
Parts of Line	8	4	4	4	4	4	8	4	4	4	4	4

(unit: metric ton)

Rated Lifting Capacity Table (3)

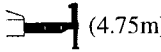
24.0m Boom + 3.6m Jib								
[Standard Hook: for 1.8 ton (Hook Weight: 25 kg), Parts of Line: 1]								
 (4.75m)								
Outriggers Fully Extended (360° Full Range)								
Boom Angle (°)	5° Offset		25° Offset		45° Offset		60° Offset	
	Working Radius (m)	Load (t)	Working Radius (m)	Load (t)	Working Radius (m)	Load (t)	Working Radius (m)	Load (t)
82	4.4	1.60	5.8	1.50	6.5	1.00	6.8	0.65
80	5.2	1.60	6.4	1.50	7.2	1.00	7.4	0.65
75	7.8	1.60	8.7	1.17	9.5	0.93	9.6	0.65
70	10.1	1.25	11.1	0.98	11.6	0.85	11.8	0.65
65	12.3	1.05	13.1	0.88	13.6	0.77	13.8	0.65
60	14.3	0.90	15.1	0.76	15.6	0.70	15.6	0.65
55	16.3	0.72	17.0	0.64	17.4	0.64		
50	18.1	0.55	18.7	0.53	18.9	0.52		
45	19.7	0.40	20.4	0.37	20.3	0.40		
40	21.1	0.28	21.6	0.27				
35	22.3	0.20	22.7	0.19				
Critical Boom Angle	34°		34°		44°		59°	

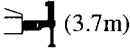
 (3.7m)								
Outriggers Intermediately Extended (Over Side)								
Boom Angle (°)	5° Offset		25° Offset		45° Offset		60° Offset	
	Working Radius (m)	Load (t)	Working Radius (m)	Load (t)	Working Radius (m)	Load (t)	Working Radius (m)	Load (t)
82	4.4	1.60	5.8	1.50	6.5	1.00	6.8	0.65
80	5.2	1.60	6.4	1.50	7.2	1.00	7.4	0.65
75	7.8	1.60	8.7	1.17	9.5	0.93	9.6	0.65
70	10.1	1.25	11.1	0.98	11.6	0.85	11.8	0.65
65	12.2	0.90	13.1	0.76	13.6	0.77	13.8	0.65
60	14.2	0.59	15.0	0.54	15.5	0.53	15.5	0.54
55	16.0	0.37	16.8	0.33	17.2	0.33		
50	17.8	0.20	18.5	0.18	18.7	0.18		
Critical Boom Angle	49°		49°		49°		59°	

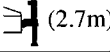
 (2.7m)								
Outriggers Intermediately Extended (Over Side)								
Boom Angle (°)	5° Offset		25° Offset		45° Offset		60° Offset	
	Working Radius (m)	Load (t)	Working Radius (m)	Load (t)	Working Radius (m)	Load (t)	Working Radius (m)	Load (t)
82	4.4	1.60	5.8	1.50	6.5	1.00	6.8	0.65
80	5.2	1.60	6.4	1.50	7.2	1.00	7.4	0.65
75	7.8	1.20	8.7	1.05	9.5	0.93	9.6	0.65
70	10.0	0.72	10.9	0.65	11.5	0.62	11.7	0.56
65	11.9	0.41	12.9	0.35	13.4	0.34	13.6	0.33
Critical Boom Angle	64°		64°		64°		64°	

(unit: metric ton)

Rated Lifting Capacity Table (4)

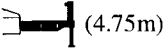
24.0m Boom + 5.5m Jib								
[Standard Hook: for 1.8 ton (Hook Weight: 25 kg), Parts of Line: 1]								
 (4.75m)								
Outriggers Fully Extended (360° Full Range)								
Boom Angle (°)	5° Offset		25° Offset		45° Offset		60° Offset	
	Working Radius (m)	Load (t)	Working Radius (m)	Load (t)	Working Radius (m)	Load (t)	Working Radius (m)	Load (t)
82	4.8	1.00	6.9	1.00	8.2	0.65	8.6	0.40
80	5.6	1.00	7.6	1.00	8.9	0.65	9.5	0.40
75	8.4	1.00	10.1	0.85	11.2	0.63	11.5	0.40
70	11.1	1.00	12.4	0.72	13.4	0.58	13.6	0.40
65	13.4	0.81	14.7	0.61	15.6	0.52	15.6	0.40
60	15.6	0.69	16.8	0.55	17.5	0.48	17.4	0.40
55	17.7	0.58	18.8	0.49	19.3	0.45		
50	19.6	0.49	20.5	0.44	20.8	0.40		
45	21.2	0.36	22.0	0.34	22.3	0.35		
40	22.9	0.23	23.4	0.24				
Critical boom angle	39°		39°		44°		59°	

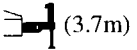
 (3.7m)								
Outriggers Intermediately Extended (Over Side)								
Boom Angle (°)	5° Offset		25° Offset		45° Offset		60° Offset	
	Working Radius (m)	Load (t)	Working Radius (m)	Load (t)	Working Radius (m)	Load (t)	Working Radius (m)	Load (t)
82	4.8	1.00	6.9	1.00	8.2	0.65	8.6	0.40
80	5.6	1.00	7.6	1.00	8.9	0.65	9.2	0.40
75	8.4	1.00	10.1	0.85	11.2	0.63	11.5	0.40
70	11.1	1.00	12.4	0.72	13.4	0.58	13.6	0.40
65	13.4	0.75	14.7	0.61	15.6	0.52	15.6	0.40
60	15.4	0.52	16.7	0.45	17.5	0.42	17.4	0.40
55	17.4	0.31	18.6	0.28	19.1	0.28		
52	18.5	0.22	19.5	0.21	20.0	0.20		
Critical boom angle	51°		51°		51°		59°	

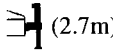
 (2.7m)								
Outriggers Intermediately Extended (Over Side)								
Boom Angle (°)	5° Offset		25° Offset		45° Offset		60° Offset	
	Working Radius (m)	Load (t)	Working Radius (m)	Load (t)	Working Radius (m)	Load (t)	Working Radius (m)	Load (t)
82	4.8	1.00	6.9	1.00	8.2	0.65	8.6	0.40
80	5.6	1.00	7.6	1.00	8.9	0.65	9.2	0.40
75	8.4	1.00	10.1	0.85	11.2	0.63	11.5	0.40
70	10.8	0.66	12.3	0.55	13.3	0.48	13.6	0.40
65	12.9	0.36	14.4	0.30	15.3	0.26		
Critical boom angle	64°		64°		64°		69°	

(unit: metric ton)

## Rated Lifting Capacity Table (5)

When Outriggers Are Not In Use

Working Radius (m)						
	Stationary on Rubber					
	5.3m Boom		9.04m Boom		12.78m Boom	
	Over Front	360° Full Range	Over Front	360° Full Range	Over Front	360° Full Range
1.5	3.60	2.80	3.60	2.80	3.60	2.80
2.0	3.40	2.80	3.40	2.80	3.40	2.80
2.5	3.10	2.15	3.10	2.10	3.10	2.05
3.0	2.65	1.60	2.60	1.55	2.55	1.50
3.5	2.30	1.25	2.20	1.20	2.10	1.10
4.0	2.00	0.90	1.90	0.80	1.70	0.70
4.5			1.60	0.50	1.40	0.40
5.0			1.30		1.10	
5.5			1.10		0.95	
6.0			0.90		0.80	
7.0			0.50		0.50	
Critical Boom Angle	-	-	26°	54°	52°	66°
Standard Hook	13t Hook					
Hook Weight	90 kg					
Parts of Line	4					

(unit: metric ton)

Working Radius (m)						
	Pick & Carry (Travelling Speed Maximum 2 km/h)					
	5.3m Boom		9.04m Boom		12.78m Boom	
	Over Front	360° Full Range	Over Front	360° Full Range	Over Front	360° Full Range
1.5	3.20	2.00	3.20	2.00	3.20	2.00
2.0	3.00	2.00	3.00	2.00	3.00	2.00
2.5	2.80	1.55	2.75	1.50	2.65	1.45
3.0	2.40	1.10	2.30	1.05	2.20	1.00
3.5	2.00	0.85	1.90	0.75	1.80	0.65
4.0	1.70	0.60	1.65	0.50	1.50	0.40
4.5			1.40	0.30	1.25	
5.0			1.15		1.00	
5.5			0.95		0.85	
6.0			0.80		0.70	
7.0			0.45		0.45	
Critical Boom Angle	-	-	26°	54°	52°	68°
Standard Hook	13t Hook					
Hook Weight	90 kg					
Parts of Line	4					

(unit: metric ton)



## Notes for the Rated Lifting Capacity Chart

### When Outriggers Are Used

- The rated lifting figures shown are the maximum guaranteed loads for when the Crane is level on flat and firm ground and includes the weight of the main hook and lifting equipment during boom operation and the weight of the auxiliary hook and lifting equipment during jib operation.  
The figures within the bold lines are based on the structural strength of the machine and those outside of the heavy lines are based on the stability of the Crane.
- The working radii are based on actual figures including the deflection of the boom and jib. For this reason operate the Crane based on the operation radius.
- The working radii of the jib are based on figures obtained when the jib is attached to a 24.0m long boom. If operating with a boom of a different length only use the boom angle as a reference.
- Do not use the jib with the outriggers at their minimum extended state.
- Depending on the outrigger extension status the side lifting (lateral) performance will differ so perform operations referring to the rated lifting capacity chart for each extension status. For front and rear lifting refer to the rated capacity lifting chart with the outriggers at maximum extension.

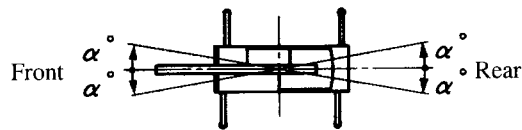

Outrigger Extension Status	Outriggers Intermediately Extended (3.7m)	Outriggers Intermediately Extended (2.7m)	Outriggers Fully Retracted
Range $\alpha^\circ$	25	15	3

- The rated lifting capacity for the rooster sheave is equivalent to the rated lifting capability for the boom minus the weight of the hook and other hoisting equipment attached to the boom and has a maximum of 1,800 kg.  
[Rooster sheave hook: 1.8 ton hook (weight 25 kg) 1 part of line].
- When the boom exceeds the specified length on the chart operate the Crane according to the rated lifting capabilities for the next longer boom length or the chart above whichever has the lowest value.
- When operating the boom with the jib attached refer to the rated lifting capacity minus the weight of additional hoisting equipment and 600 kg. Do not use the rooster sheave with the jib attached or the boom with the jib attached if the outriggers are at minimum extension.
- The critical boom angles during each operation are as shown in the chart. If these critical angles are exceeded the Crane will tip over even without a load.

## Notes for the Rated Lifting Capacity Chart

### When Outriggers Are Used

10. The parts of standard hook line required for each boom length is as stated in the chart. When the standard number of parts of line is not used each wire rope is limited to 15.7kN (1.6ft).
11. When using the jib in situations where the jib offset angle exceeds the specified angle operate using a jib offset one stage larger as a rough guide.
12. The free fall option is designed to lower the hook only. Avoid sudden operation of the lever.
13. Crane operation is possible in wind speeds up to 10m/sec however even when the wind is relatively weak pay extra if handling a hanging load that has a large wind reception area.
14. If operating with loads exceeding those specified or using the Crane in an incorrect manner the Crane will tip over or be damaged. The equipment warranty will not be valid in this situation.

## Notes for the Rated Lifting Capacity Chart

### When Outriggers Are Not Used

1. The rated lifting figures shown are the maximum guaranteed loads for when the Crane is level on flat and firm ground with the weight of the hook and all other hoisting equipment included, the suspension lock cylinder in its most reduced state and with the tyres at the specified pressure.  
[Specified tyre pressure: 875 kPa (8.75 kg/cm<sup>2</sup>)]

The figures within the bold lines are based on the structural strength of the Crane and those outside of the bold lines are based on the stability of the machine.

2. The working radii are based on figures including the deflection of the boom. For this reason operate the Crane based on the operation radius.
3. The rated lifting capability of forward capability and entire capability is different. When slewing from front lifting to side lifting there is the possibility of overloading so exercise extreme care.

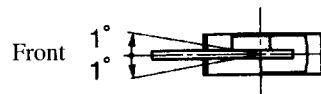

4. The rated lifting capacity for the rooster sheave is equivalent to the rated lifting capability for the boom minus the weight of the hook and other hoisting equipment attached to the boom and has a maximum of 1,800 kg.  
[Rooster sheave hook: 1.8 ton hook (weight 25 kg) 1 part of line]
5. Do not operate the boom, jib or free fall operation with the boom longer than 12.78m.
6. When performing stationary lifting operate with the parking brake and the brake lock on at the same time.
7. When mobilizing place the shift lever in 1st.
8. When mobilizing hold the load close to the ground to prevent swinging and travel at less than 2 km/h. Be particularly careful when turning corners, starting and stopping.
9. When mobilizing do not operate the Crane and be sure to have the slewing brake on.
10. When the boom exceeds the specified length on the chart operate the Crane according to the rated lifting capabilities for the next longer boom length or the chart above, whichever has the lowest value.
11. The critical boom angles during each operation are as shown in the chart. If these angles are exceeded the Crane will tip over even without a load.
12. The parts of standard hook line required for each boom length is as stated in the chart. When the standard number of parts of line is not used each wire rope is limited to 15.7kN (1.6ft).

## Notes for the Rated Lifting Capacity Chart

### When Outriggers Are Not Used

13. Crane operation is possible in wind speeds up to 10m/sec however even when the wind is relatively weak pay extra if handling a hanging load that has a large wind reception area.
14. If operating with loads exceeding those specified or using the Crane in an incorrect manner the crane will tip over or be damaged. The equipment warranty will not be valid in this situation.

# Working Range Diagram

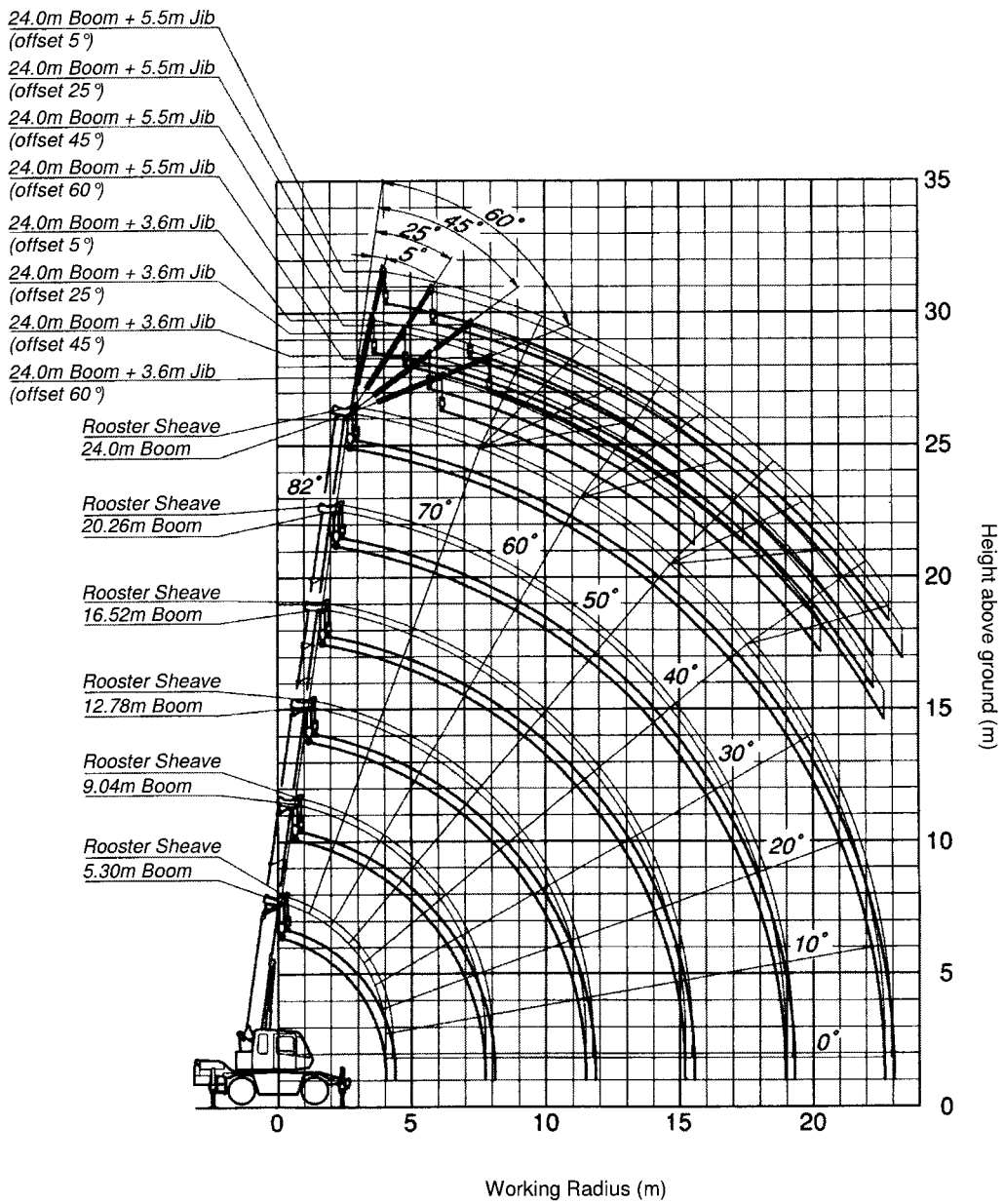

## Caution

1. The diagram above does not allow for boom and jib deflections.
2. The chart above is based on operation with all outriggers at full extension.

## Minimum Road Width for Right-Angle Turn

### Right Turn in 2-Wheel Steering Mode

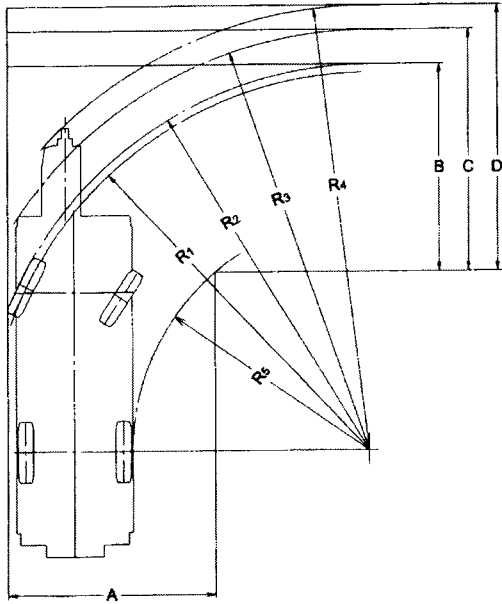

- $R_1 = 6.50\text{m}$   
(Minimum Turning Radius)
- $R_2 = 6.64\text{m}$   
(Turning Radius of Extremely Outer Tyre)
- $R_3 = 7.23\text{m}$   
(Chassis Turning Radius)
- $R_4 = 7.65\text{m}$   
(Boom End Turning Radius)
- $R_5 = 4.03\text{m}$   
(Vehicle Interior Turning Radius)
- $A = 3.57\text{m}$  (Width of Entrance)
- $B = 3.57\text{m}$  (Width of Wheel Exit)
- $C = 4.16\text{m}$  (Width of Chassis Exit)
- $D = 4.57\text{m}$  (Width of Exit at End of Boom)

### Right Turn in 4-Wheel Steering Mode

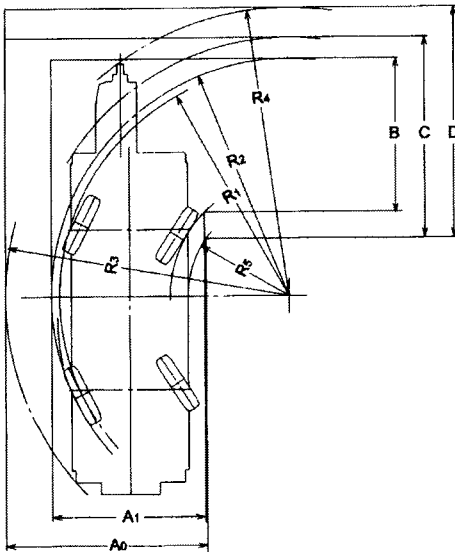

- $R_1 = 3.92\text{m}$   
(Minimum Turning Radius)
- $R_2 = 4.06\text{m}$   
(Turning Radius of Extremely Outer Tyre)
- $R_3 = 4.85\text{m}$   
(Chassis Turning Radius)
- $R_4 = 4.94\text{m}$   
(Boom End Turning Radius)
- $R_5 = 1.72\text{m}$   
(Vehicle Interior Turning Radius)
- $A_0 = 3.44\text{m}$  (Width of Entrance)
- $A_1 = 2.62\text{m}$  (Width of Wheel Entrance)
- $B = 2.62\text{m}$  (Width of Wheel Exit)
- $C = 3.44\text{m}$  (Width of Chassis Exit)
- $D = 3.95\text{m}$  (Width of Exit at End of Boom)

Note: The above figures are calculated values