

## Dimensions Maeda MC305

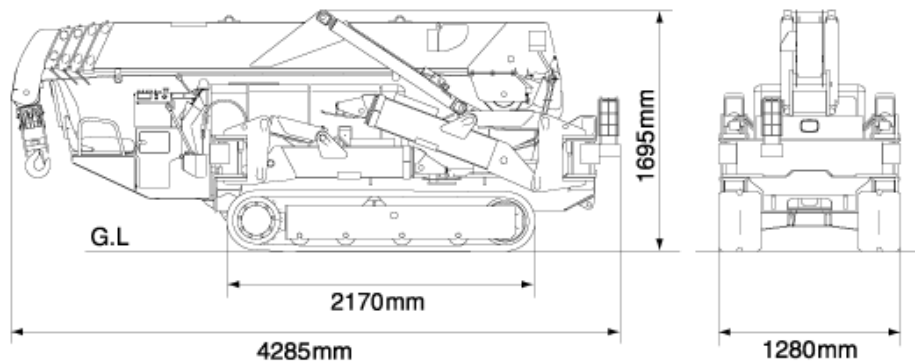

## Technical specifications

Model		MC305CRM(E)-2	
Crane capacity	txm	2.98t x 2.5m	
Max. working radius	mxt	12.16m x 0.26t	
Max.lifting height (on the ground)	m	12.52m	
Max.lifting height (underground)	m	-16.09m (4 falls)	
Winch system	Hook speed	m/min	13.5m/min (4 layers, 4 falls)
	Hoist wire rope	Øxm	IWRC 6xWS(26) Ø8x73m
Telescoping system	Type		Fully automatic 5-section pentagonal telescopic boom
	Boom length	m	3.695~12.485m
	Boom telescoping stroke / time	m/sec	8.79m/26sec
Boom hoist system	Hoist angle / time	deg/sec	0~80deg/14.5sec
Swing system	swing angle / time	deg/rpm	360deg/2.4rpm
Outrigger system	Type		Extended Hydraulic cylinder direct acting Setting up Hydraulic cylinder direct acting
	Max.extended width	mm	(Lateral)4,888x (Front)4,504x (Rear)4,396
Travel system	Type		Hydraulic motor driven , stepless speed changer
	Travel speed	km/h	0~2.8
	Gradability	deg	23
	Crawler ground length x width	mm	1750 x 300
	Ground pressure	kpa [kgf/cm <sup>2</sup> ]	36.3 [0.37]
Engine	Model		YANMAR 3TNV76
	Displacement	L [cc]	1.115 [1,115]
	Rated output	kw/min <sup>-1</sup> [ps/rpm]	15.2kw/2500min <sup>-1</sup> [20.7PS/2500rpm]
	Starting method		Electric starting
	Fuel / Fuel tank capacity	L	Diesel/40.0
Motor (MC305CRME-2)	Motor type		Totally enclosed fan-cooled motor 5.5kw, 4P 200V or 380V
	Starting system		Inverter system (30Hz-60Hz)
Remote control system	Type		Cable remote controller
	Micro/High speed mode		Available
	Load display for transmitter		Available
	Outrigger operation		Available
	Voice		Available
Overall length x width xheight	mm	4,285 x 1,280 x 1,695	
Machine weight	kg	3,900kg (4,040kg with electric motor)	
Safety device		Overwind protection, Load indicator, Hydraulic safety valve, Wire rope latch, Level, Machine body inclination alarm, EMO switch, Travel lock lever, Outrigger interlock device Moment limiter, Rotary lamp	
Options		White rubber track, Single fall hook, Searcher hook	

## Working Range Chart

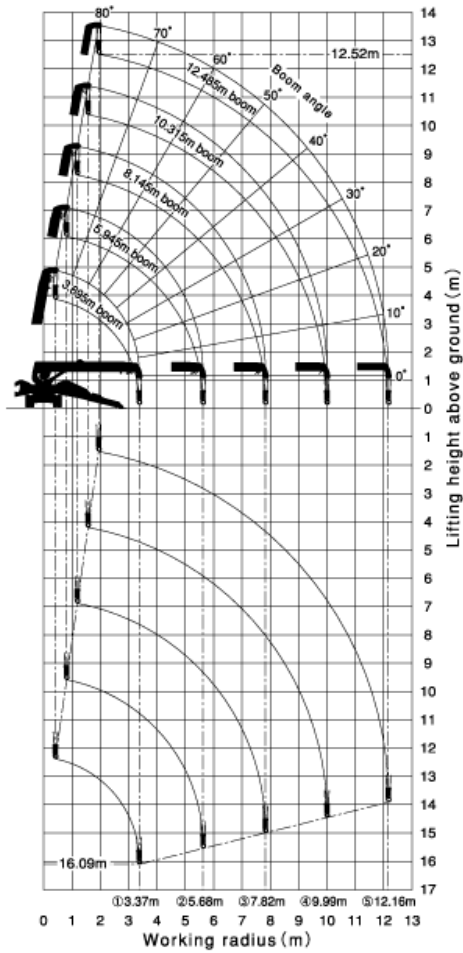

\*The working range chart applies to cases without load and do not include boom deflections.

**HAWKESBURY**  
**CRANES** PTY. LTD  
**0418 451 120**

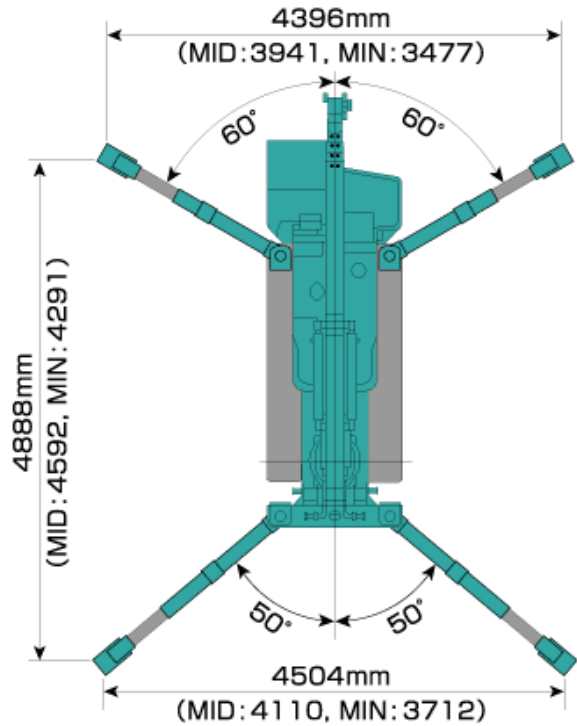

## Total Rated Load Chart (4 falls)

Total Rated Load Chart with outrigger extended to maximum

5.945m Boom		8.145m Boom		10.315m Boom		12.485m Boom	
Working Radius (m)	Total Rated Load (kg)	Working Radius (m)	Total Rated Load (kg)	Working Radius (m)	Total Rated Load (kg)	Working Radius (m)	Total Rated Load (kg)
2.5 or less	2980	2.7	2270	4.0	1080	4.5 or less	790
3.0	2390	3.0	2120	4.5	985	5.0	660
3.5	1990	3.5	1680	5.0	880	6.0	520
4.0	1710	4.0	1440	6.0	770	7.0	430
4.5	1490	4.5	1260	7.0	670	8.0	380
5.0	1340	5.0	1110	8.0	570	9.0	340
5.62	1160	5.5	990	9.0	500	10.0	310
		6.0	880	9.99	435	11.0	280
		7.0	730			12.16	260
		7.82	630				

\* The Total Rated Load Chart is based on actual working radius with the bending of boom attributable to load reflected and is shown with the mass of hook (30kg) included.